

# SP 750-15 / SP 750-18 / SP 1000

Trailer Mounted  
Concrete Pumps



## DON'T BACKDOWN FROM A PUMPING PROJECT

- Output to 70 cu.yds./hr.
- Pressure up to 1100 psi
- 1.5" Max. Aggregate



*Model shown with optional dual axles.*

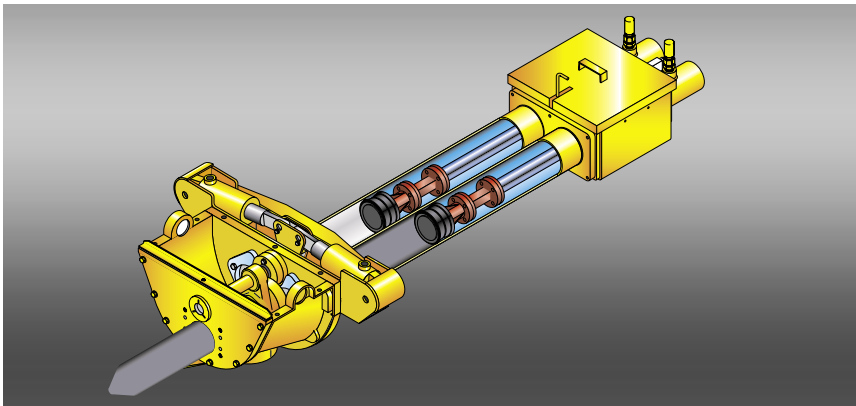

*This all-hydraulic concrete pump sets the standard for fuel-efficiency, reliability and performance. Twin circuit hydraulics combine with standard dual shifting cylinders, agitator and Long Rock Valve™ to provide smooth pumping of harsh mixes, shotcrete and grout. Fast cleanout adds more jobs per day with the lowest per yard operating costs.*



*Convenient control panel includes electric switches for on/off, forward/reverse and agitator on/off. Tachometer and hour meter are also located here along with E-stop,*



Choose an SP 750 or SP 1000 and you will be amazed at the pumping performance you can achieve. From medium rise buildings to 1,000-foot plus horizontal placements you can do it all. Owners report years of continuous service with only regular maintenance pumping grout for block fill, structural concrete on commercial projects and high volume shotcrete. These affordable SPs have all of the features you need to handle a wide range of mixes at volumes that meet the needs of most projects.

The compact size of the SP Models means easy towing to the job. And fast cleanout of the Rock Valve™ adds more jobs per day for more profits. Schwing all-hydraulic design is the key to ultra-reliable operation that pays off whether you are a pumper or concrete contractor. And easy access to maintenance points means your SP will be providing a generous return on investment for years to come through long-term use.

So don't back down from harsh mixes, 24/7 operation or high volume pours at impressive distances. Three models provide all the pumping performance you need. The SP 750s vary by output and the SP 1000 adds horsepower to achieve higher volume at longer distances. All models come standard with LED taillights and aluminum wheels.



*Remote control (cable or optional radio remote ) frees the operator to monitor the end hose and the pump. Critical functions including on/off and forward/reverse are*



*Fuel efficient Deutz diesel is an example of the high quality components on our trailer pumps. Here is an engine that was designed for construction applications and is up to the*



*Fast cleanout with less wasted concrete is a benefit of these SP models over other pumps. The standard hopper agitator keeps concrete flowing to the material cylinders for smooth*

---

Only one manufacturer can supply the Schwing experience.

Thousands of our customers form a backdrop of success that you can join by letting us spec the right piece of equipment for your needs. Six company stores with technicians and parts placed strategically across the country provide service expertise as close as your phone. And a select group of knowledgeable dealers provides another layer of invaluable experience. You and your staff will be welcomed into our facility to learn how to extract the maximum profitability from your concrete pump.

Generations of successful owners have chosen the Schwing experience. As a third generation family owned company we understand how important quality equipment is to your business and how important your business is to us.



*The stationary pump plant in Atlanta is a modern model of efficiency, manufacturing pumps in trailer, skid or truck-mounted configurations for contractors around the world. From close inspection of incoming materials to forming our products with the latest welding techniques, Schwing takes craftsmanship to the highest standards. Our state-of-the-art paint facility produces finished products you will be proud to put your name on. In addition, a vast inventory of parts are on hand to keep your Schwing product running at maximum effi-*

# SPECIFICATIONS

## PUMP SPECIFICATIONS

	SP 750-15		SP 750-18		SP 1000	
	U.S.	Metric	U.S.	Metric	U.S.	Metric
Concrete Output Per Hour (cubic yards-cubic meters)	50	38	70	54	70	54
Maximum Pressure on Concrete (psi-bar)	1100	76	1100	76	1100	76
Maximum Aggregate Size (in.-mm)	1.5	38	1.5	38	1.5	38
Maximum Horizontal Pumping Distance* (feet-meters)	1160	354	1160	354	1160	354
Maximum Vertical Pumping Distance* (feet-meters)	330	100	330	100	330	100
Concrete Cylinder Diameter (in.-mm)	6	150	7	180	7	180
Differential Cylinder Diameter (in.-mm)	3.14/1.97	80/50	3.54/1.97	90/50	3.54/1.97	90/50
Concrete Cylinder Stroke Length (in.-mm)	39	1000	39	1000	39	1000
Maximum Pump Strokes Per Minute	35		35		35	
Main Hydraulic Pump	A11V095		A11V095		A11V095	
Volume Control	0 to Maximum		0 to Maximum		0 to Maximum	
Concrete Valve Type	Long Rock™		Long Rock™		Long Rock™	
Shifting Cylinders	2		2		2	
Hydraulic Tank Capacity (gallon-liters)	70	265	70	265	70	265
Hydraulic System	Open Loop		Open Loop		Open Loop	
Hopper-Height (in.-mm)	51	1300	51	1300	51	1300
Hopper Capacity (cubic feet-cubic meters)	11	.31	11	.31	11	.31
Outlet Diameter (in.-mm)	5	125	5	125	5	125
Engine Model - Tier II	Deutz BF4M2012		Deutz BF4M2012		Deutz BF4M2012C	
Engine Model - Tier III	Deutz TCD2012-100		Deutz TCD2012-100		Deutz TCD2012-133	
Engine Power (horsepower-kilowatt)	100	75	100	75	133	99
Fuel Tank Capacity (gallon-liter)	30	114	30	114	30	114
Axle	Single Standard		Single Standard		Single Standard	
Axle Capacity Rating (pounds-kilograms)	8000	3628	8000	3628	8000	3628
Tires	ST 215/75 R17.5		ST 215/75 R17.5		ST 215/75 R17.5	
Dual Axle Tires	LT 215/85 R16		LT 215/85 R16		LT 215/85 R16	
Brakes	Electric		Electric		Electric	
Outrigger Legs	Manual Standard		Manual Standard		Manual Standard	
Length (in.-cm)	184	468	184	468	184	468
Width (in.-cm)	66	168	66	168	66	168
Height (in.-cm)	83	211	83	211	83	211
Trailer Units Weight (pounds-kilograms)	7100	3220	7350	3334	7500	3402
Remote Control Cable (feet-meters)	100	30	100	30	100	30

\*Pumping distances shown are to be used as a guide only since they have been considerably exceeded on specific projects. Maximum attainable distances depend upon concrete mix design and pipeline diameter. Maximum output and distance cannot be achieved simultaneously.

\*\*Pump specifications are for standard units. Other units are available.

**SP 750-15 / SP 750-18 / SP 1000**

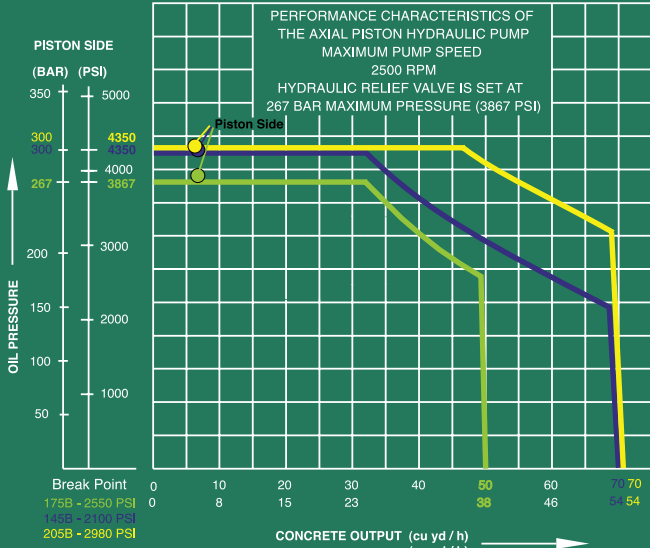

**SP 750-15**

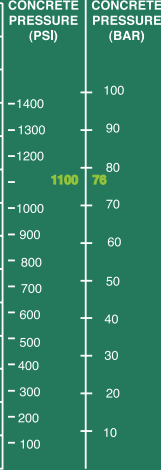

**SP 750-18  
SP 1000**

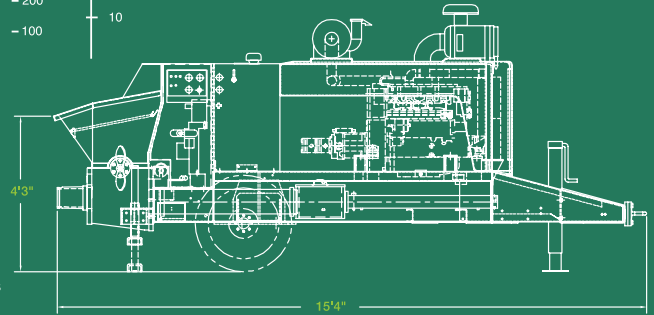
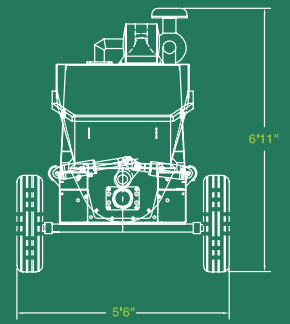

**SP 750-15**

PISTON SIDE



**SP 750-18  
SP 1000**

PISTON SIDE



# SCHWING-STETTER MOVES CONCRETE. WORLDWIDE.

Wherever concrete is produced and moved is where you will find Schwing-Stetter machinery.

With plants in Germany, Austria, USA, Brazil, Russia, China and India as well as with more than 100 sales and service facilities, the group of companies is always close to the customer.

Our wide range of products with something for every application is what makes Schwing-Stetter the No. 1 system supplier for concrete machinery worldwide.



**CONCRETE BATCHING PLANTS**



**TRUCK MIXERS**



**TRUCK-MOUNTED CONCRETE PUMPS**



**STATIONARY CONCRETE PUMPS**



**SEPARATE PLACING BOOMS**



**CONCRETE RECYCLERS**

